

Robotheca Alexandrina Olympiad (RAO)

“Sunken Antiquities: Saving Cleopatra”

27–28 November 2013

Competition Manual

Table of Contents	Page
1. General Information	3
1.1 Venue	3
1.2 Target Age	3
1.3 Registration	3
2. General Rules	4
3. Diving Robots Category	6
3.1 Theme introduction	6
3.2 Mission description	8
3.3 Playing field dimensions and description	8
3.4 Robots specs	9
3.5 Starting zone	9
3.6 Scoring	9
3.7 Matches (Rounds)	10
3.8 Touch penalties	10
4. Robo-Fight Category	12
4.1 Playing field	12
4.2 Robots specs	12
4.3 Mission and scoring	13
4.4 Matches (Rounds)	14
4.5 Touch penalties	14

5. Judging	15
6. Best Robots Presentations	15
7. Awards	15
8. Technical Support	15

1. General Information

The Robotheca Alexandrina Olympiad (RAO) will be comprised of two categories: Diver Robot category, and Robo-Fight category

1.1 Venue

Trial contests will be held at the Multipurpose Hall area.

Competition contests, opening and closing ceremonies will be held at the Great Hall.

1.2 Target age

For the Diver Robot category, the age of contestants should be 12–18 years, while the maximum number of team members is five and one coach.

For Robo-Fight category, the age of contestants should be 12–14 years, while the maximum number of team members is three members and one coach.

1.3 Registration

Registration fees are EGP 500 per team for the Diver Robot category, and EGP 350 for the Robo-Fight category. Registration of the teams will be on the PSC website at the following link:

<http://www.bibalex.org/en/psc/GetInvolved/Robotheca.aspx>

Registration Fees will be paid on-site. Registration deadline will be announced on PSC website.

2. General Rules

- In the Diving Robot category
 - The Tournament Draw: A Draw will be on 27 November 2013. Teams will know their assigned competition based on their number in the draw.
 - Final scores: Teams will be divided into groups, and the winner of each group will join the semifinal and the final stages.
 - Following the match, no team is allowed on the playing field, and if that occurs the Judge will consider 20 points as penalty for the team.
 - Design Exam
 - In addition to the scores, all contestants' robots will be evaluated through a "Design exam" of 50 points, which will evaluate the Technical merits in movement and operation of competing robots; the following perspectives will be considered: mechanical design, electronic design and programming.
 - Design and fabrication of a robot without using entirely LEGO or Parallax components, or any other kit, will be considered an advantage in the Design exam.
 - The Judge will ask the team to run the robot to examine its functions.

- In the Robo-Fight category

The Olympiad will be accommodating a maximum of 16 teams, playing 8 matches; the 4 winners of those matches will play two semifinal matches; the two winners of such matches will play one final match, which will determine the winner.

- Restrictions on Robot Design
 - Jamming devices, intended to saturate the opponent's sensors, are not allowed.
 - Do not use parts that could break or damage the playing field. Do not use parts that are intended to damage the opponent's robot or its operator. Normal pushes and bangs are not considered an intent to damage.
 - Do not include, in a robot's body, devices that can store liquid, powder, or air, which are thrown at the opponent.
 - Do not use any inflammable devices.
 - Do not use devices that throw out things at your opponent.
 - Do not stick a robot down onto the Playing Field, using suction devices or glue, or use any type of sticky tires (such as double stick foam tape) or any device to assist in adding additional down force (such as a vacuum device).

- **Coaches Meeting**

The organizers will hold two meetings with the team coaches to ensure that all roles are clear and to answer their queries. The first meeting will be held with the accepted teams after the registration process, then the other meeting will be during the first day of the competition.

- **Code of Conduct**

The Judge will be monitoring the attitude of the players during the competition. In case the Judge has detected any misconduct from any of the players, the Judge will raise the red flag to announce the need for the interference of the Chair of the Olympiad Judging Committee, who will have the final call to terminate the contest in favor of any of the players.

3. Diving Robot Category

3.1 Theme Introduction

Alexandria was among the largest and most magnificent cities in Antiquity. Founded by Alexander the Great, in 331 BCE, the architecture and culture of Rome itself were overshadowed by the Egyptian city. Palaces and temples dominated the skyline. The beauty of this political, religious, cultural and scientific capital aroused the admiration of visitors such as Strabo, the Greek geographer. The population had already passed the 100,000 mark shortly after Alexandria's founding. The city's c. 130 meters high Pharos Lighthouse represented one of the Seven Wonders of the Ancient World. Alexandria was also famous for its huge Library with about half-a-million scrolls of papyrus. Parts of the city's Royal Quarter with its temples, palaces, royal gardens and harbor structures were situated in the Eastern Harbor, known as the Portus Magnus. Here, on the Island of Antirrhodos and the Poseidonium Peninsula, Julius Caesar, Marc Anthony and Cleopatra stayed.

Due to a combination of natural phenomena, including a series of earthquakes and tidal waves, the Portus Magnus and parts of the city's ancient coastline sank beneath the Sea. For more than 1200 years, temples, buildings, palaces, statues, ceramics, coins, jewelry and everyday objects lay untouched on the seabed covered by thick layers of sand and sediment.

The Sunken City lies outside Fort Qaitbey, covering much of the Eastern Harbor. Most of it lies at about 8 meters depth. It is not yet part of the tourist attraction of Alexandria, it is still being examined by archaeologists.

It contains structures belonging to Ptolemaic and Roman Eras. To a large extent this is the lost ancient city of Alexandria. In the area, so far one pharaonic statue and 25 sphinxes have been located, together with several statues of gods and one of Cleopatra. The Sunken City is the outcome of several natural catastrophes, such as earthquakes and tidal waves. It was lost to the Sea sometime in the fourth century CE.



A diver eye-to-eye with a sphinx made out of black granite. The face of the sphinx is believed to represent Ptolemy XII, father of famous Cleopatra VII. The sphinx was found during excavations in the Ancient Harbor of Alexandria.



This granite head (80 cm) is attributed to Caesarion (Ptolemaios XV), son of Cleopatra VII and Julius Caesar. It is part of a statue of about 5 meters in height, and dates from the first century BCE. It was found in Alexandria's Ancient Harbor opposite the Island of Antirrhodos.

Widely known today as simply Cleopatra, Cleopatra VII Philopator (late 69 BCE–12 August 30 BCE) was the last pharaoh of Ancient Egypt.

She was a member of the Ptolemaic Dynasty, a family of Greek origin, who ruled Egypt following Alexander the Great's passing away. The Ptolemies, throughout their Dynasty, spoke Greek and refused to speak Egyptian. However, Cleopatra did learn to speak Egyptian, one of at least seven languages she spoke, and became an expert linguist. This skill would later help her command a navy, and author books. In addition, she immersed herself in Egyptian religious beliefs and customs, and represented herself as the reincarnation of the Egyptian goddess Isis. Though popular culture may portray her as a temptress who used her beauty to seduce two of the most powerful men of her time, records reveal otherwise. Cleopatra's most alluring assets were probably her intelligence, wit and demeanor. It was a combination of these features that most likely distinguished her from other women, and eventually attracted Julius Caesar and Marc Anthony.



One of the finest finds from the Aboukir Bay is a remarkable Greco-Egyptian statue of the Ptolemaic Era, a statue of a Ptolemaic queen in dark stone wearing the usual robe that identifies the sovereigns of Isis incarnate. The statue is certainly one of the queens of the Ptolemaic Dynasty. Most likely, a representation of Cleopatra II or Cleopatra III, dressed as goddess Isis. The hair with plaited tresses are handled with entirely naturalistic detail, is crowned with a diadem decorated with the uraeus-snake.

3.2 Mission Description

The Playing Field design will be as hereunder:

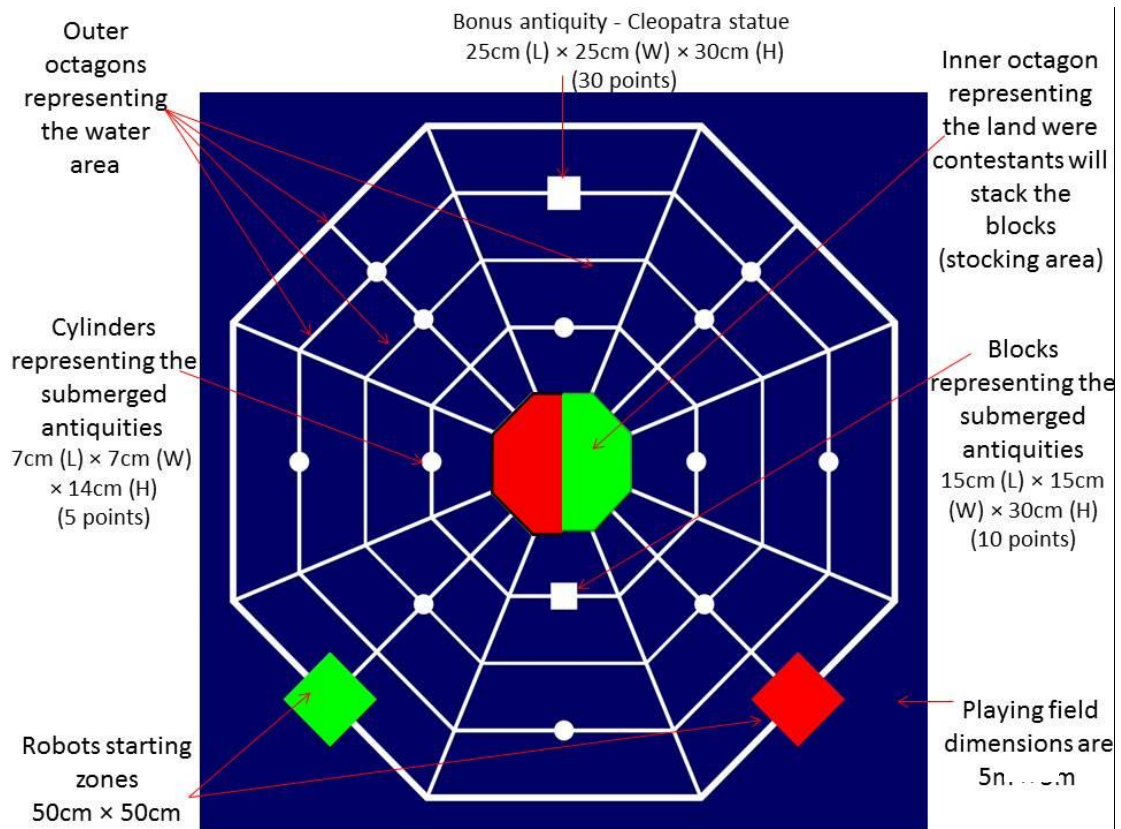

Two robots will be competing simultaneously in the same playing field. The mission entails moving the cylinders and blocks (Sunken Antiquities) from the outer circles representing the water area, to the inner circle representing the land area, where the antiquities are stored and stacked.

The time assigned for mission completion is 3 minutes; during this period the two competing robots should try to move as many cylinders and blocks as they can.

3.3 Playing Field dimensions and description

Playing field will be 5 m x 5 m in dimension. Colors: Blue with white lines; the stocking zones are green and red; starting zones are green and red; dimensions are 50 cm (L) x 50 cm (W). The distance between the white lines is 50 cm, and each white line is 3 cm in thickness. Two different color zones will be placed in the inner most octagon; each will be assigned to a team for stocking all its saved antiquities represented by the cylinders and blocks. The stocking zones are bounded with fence, which is 5 cm high.

The Playing Field includes three types of Sunken Antiquities:

- 12 cylinders, which represent the least valuable sunken antiquities; dimensions are 7 cm (L) x 7 cm (W) x 14 cm (H).
- One small block, which represents a higher value antiquity; dimensions are 15 cm (L) x 15 cm (W) x 30 cm (H).
- One large block, which represents Cleopatra statue, the highest in value; dimensions 25 cm (L) x 25 cm (W) x 30 cm (H).

3.4 Robot Specs

- Robot should operate with maximum power supply of 24V.
- Robot dimensions in the starting zone must not exceed 50 cm (L) × 50 cm (W) × 50 cm (H).
- Number of robots for one team is limited by the overall weight, which is 20 kg, and they all must fit the dimensions of the starting zone.
- Robot must be autonomous, and could be assembled from any kit.
- Robot motion will be over all the playing field, and the white lines can be used for line tracking to help the robot in carrying out its mission.

3.5 Starting Zone

- Robot dimensions must not exceed the starting zone dimensions which are 50 cm (L) × 50 cm (W).
- Robots must be completely inside the Starting Zone before commencing the contest.
- If the robot is moved back to the Starting Zone to resume its mission by the contestant, it must be completely situated inside the zone. The previous rule is not applied in case the robot touches the Zone during its mission.

3.6 Scoring

- Contestants will gain points for moving the sunken antiquities from the water area (outer large octagons) to the stocking zone (inner small octagon) as follows:
 - 5 points will be given to contestants for moving one cylinder from its location to the stocking zone.
 - 10 points will be given to contestants for moving the small block from its location to the stocking zone.
 - 30 points will be given to contestants for moving the bonus block (Cleopatra statue) from its location to the stocking zone. The team must move at least one cylinder to the stocking zone before moving the Cleopatra statue.
 - The cylinders and blocks must at least touch the stocking zone to be counted.
 - If the robot dropped one of the blocks or cylinders, the Judge will return the block back to its place, and the score of moving it will not be counted for the playing team.
 - The total score is 100 points.

Scoring Sheet

The total score for this category is as follows:

Item	No.	Points	Total Points
Robot Mission scores			
Cylinders	12	5	60
Smaller block	1	10	10
Cleopatra statues	1	30	30
Subtotal			100
Design Exam	---	50	50
Total			150

3.7 Matches (Rounds)

- Number of rounds is three, and each match will be 3 minutes.
- Teams must be at the matches area/playing field 10 minutes before the contest starting time.
- If any team does not attend any of its assigned matches, this team will lose the total points of this match, and the opponent team will play this round alone.
- If two teams end up having the same total scores, resulting from playing in their assigned three rounds and their robot score in the Design exam, the Judge will hold a new match to determine the winner.

3.8 Touch Penalties

- If the robot malfunctioned during the match, the playing team member is allowed to move it back to the Starting Zone, and the team will lose (3) points.
- If the team member touched the robot outside the Starting Zone, the team member should move it back to the Starting Zone and will lose (3) points.
- If one of the two playing team members intentionally touched the other team's robot, this will lead to disqualifying the team and this match will be cancelled, and the other team will be considered the winner.
- The playing teams are allowed to touch their robot with no penalties, only if any of its parts is touching or inside the Starting Zone.
- If the two teams' robots clinched together during the match, each team member of the playing teams is allowed to move its robot back to the Starting Zone with no penalties following the Judge's approval.
- General Conditions for Robot Position and Scoring Items: Robot Start Position (Completely In position)

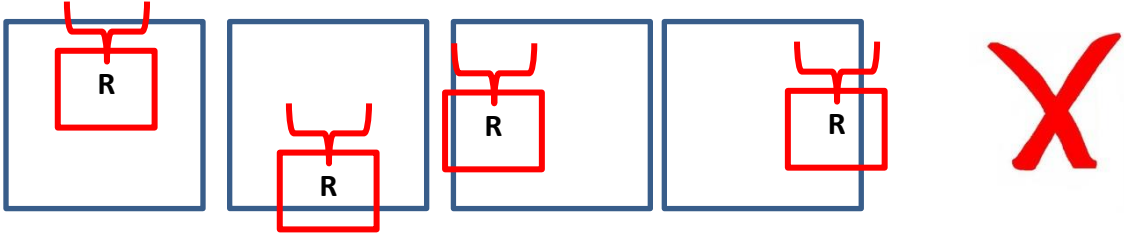
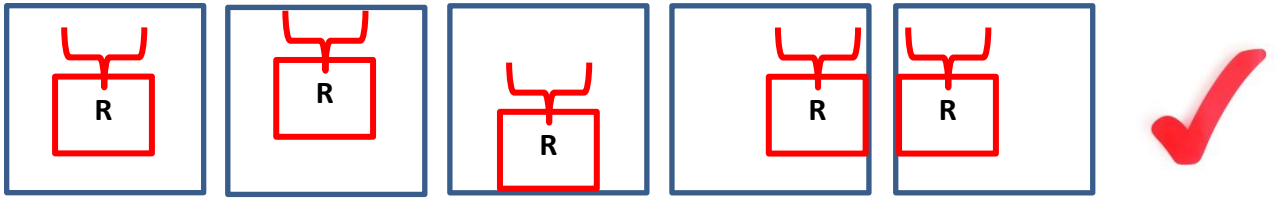

For Scoring Objects (cylinders and blocks)

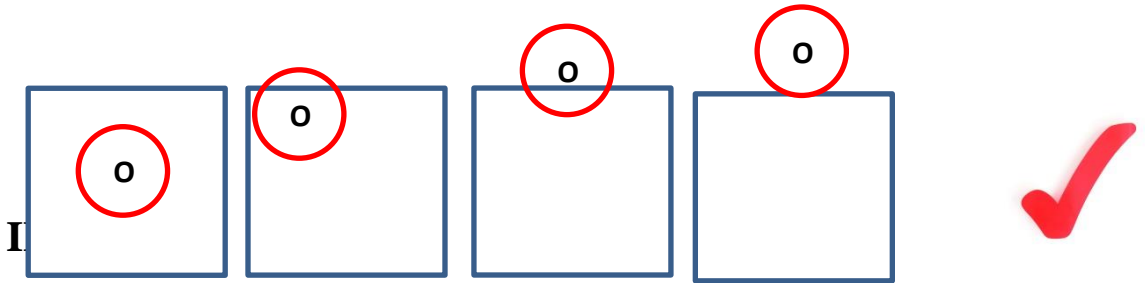

4. Robo-Fight Category

This manual presents all the roles to be followed by each team to compete in this Robot contest.

This Robot contest will ask the teams to compete through Robot matches and Design exam. The winners will be those with the highest total score in both.

4.1 Playing Field

Dimensions: 70×70 cm; square shaped.

Colors: White playing field with black boarder. Starting Zones are the green lines in the middle of the playing field.

Starting position: There are two green lines, and each robot will stand behind one of the green lines.

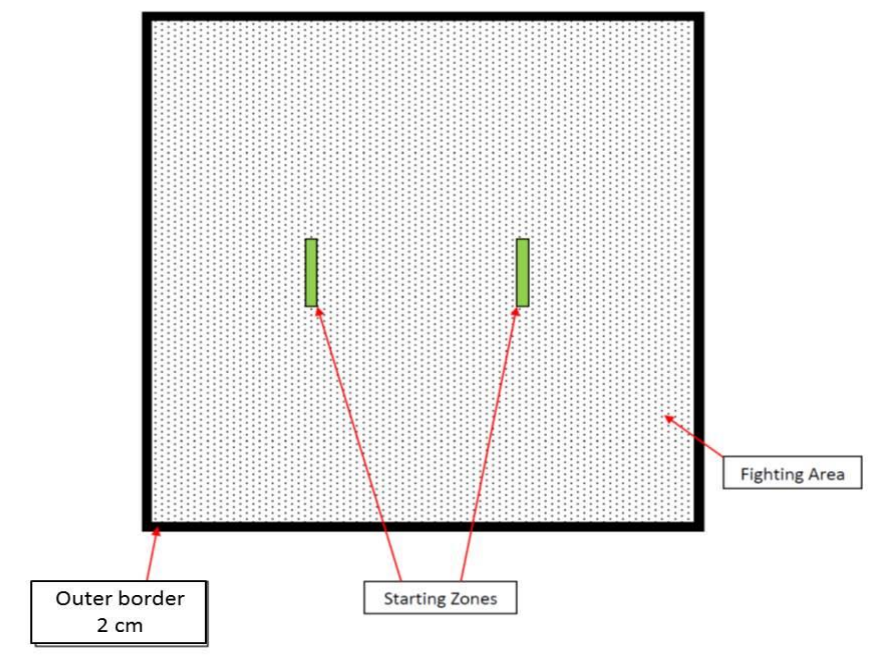

4.2 Robot Specs

- Robot must operate with a power supply of 12V maximum.
- Dimensions must not exceed 20 cm (L) \times 20 cm (W) \times 20 cm (H).
- Robot's weight must not exceed 1000 grams.
- Teams must build one robot only.
- Robot must be autonomous, and could be assembled from any kit.
- Robot motions will be inside the playing field.
- The allowed sensors to be used in the Robot design are as follows:

No.	Sensor Type	Number
1.	Ultrasonic Sensor	1
2.	IR Sensor	2
3.	Line tracking sensor	2

4.3 Missions and Scoring

- Before the starting signal of the Judge, the two robots must be behind one of the green lines.
- Starting of the Competition will be following the Judge signal.
- The robot must push its opponent robot outside the playing field to be completely out. In this case, the team of the pushing robot will be the winner.
- One point shall be given when:
You have forced the body of your opponent's robot to touch the space outside the Playing Field, which includes the side of the Playing Field itself.
- One point is also gained in the following case:
Your opponent's robot has touched the space outside the Playing Field, by itself.

When a robot has fallen on the playing field or in similar conditions, one point will not be counted for the opponent team's robot. However, if the falling robot's team touched the robot to set it back in the upright position, a touch penalty will be counted, and the match continues.

The contest shall be stopped, and shall be restarted when:

- Both robots are in clinch, and stop movements for 5 seconds, or move in the same orbit, with no progress. If it is not clear if progress is being made or not, the Judge can extend the time limit for a clinch or orbiting robots up to 30 seconds.
- Both robots move, with no progress, or stop (at the exact time) and stand still for 5 seconds without touching each other. However, if one robot stops its movement first, after 5 seconds, it shall be considered not having the will to fight, and the opponent shall receive one point, even if the opponent also stops. If both robots are moving, and it is not clear if progress is being made or not, the Judge can extend the time limit up to 20 seconds.
- If both robots touch the outside of the playing field simultaneously, the match is called to an end.

When the Judge has to decide the winner, the total score for the contest is calculated as follows.

Teams	Fighting points	Penalties	Total points
Team A			
Team B			

4.4 Matches (Rounds)

The contest shall be between two teams competing to gain the effective points, within the perimeter of the defined fighting field. The Judges will decide which team wins. One team consists of one robot with maximum three team members, one of which is a leader and the other team members must observe from the audience. A single person can also compete with a fighting robot, with the same rules that apply to teams.

- The match will be 3 minutes.
- Teams must be at the contest area 10 minutes before the starting time.
- If any team does not attend any of its assigned matches, this team will be considered a loser, and the opponent team will be the winner.
- The robot must push the other one outside the Playing Field to be completely out. In this case, this team will be the winner.
- The contest stops and resumes when a Judge announces so.

4.5 4.5 Touch Penalties

- If the robot malfunctioned during the contest, it is not allowed that the playing team member touch it, or move it back to the Starting Zone.
- If there is interference between the two teams' robots, each team member of the playing teams is allowed to move its robot back to the starting lines with no penalties following the Judge's approval.
- If a team touched the robot without the Judge's approval during the contest, the Judge will cancel the match, and the other team will be the winner.
- If the team member of a falling robot touched its robot to return it to the upright position after the Judge's approval, a touch penalty will be counted and the match continues.
- In case any of the competing teams has not scored any fighting points and only fouled for touch penalties, his score will be negative.
- General Conditions for Robot Position and Scoring Items: **IN & OUT positions**

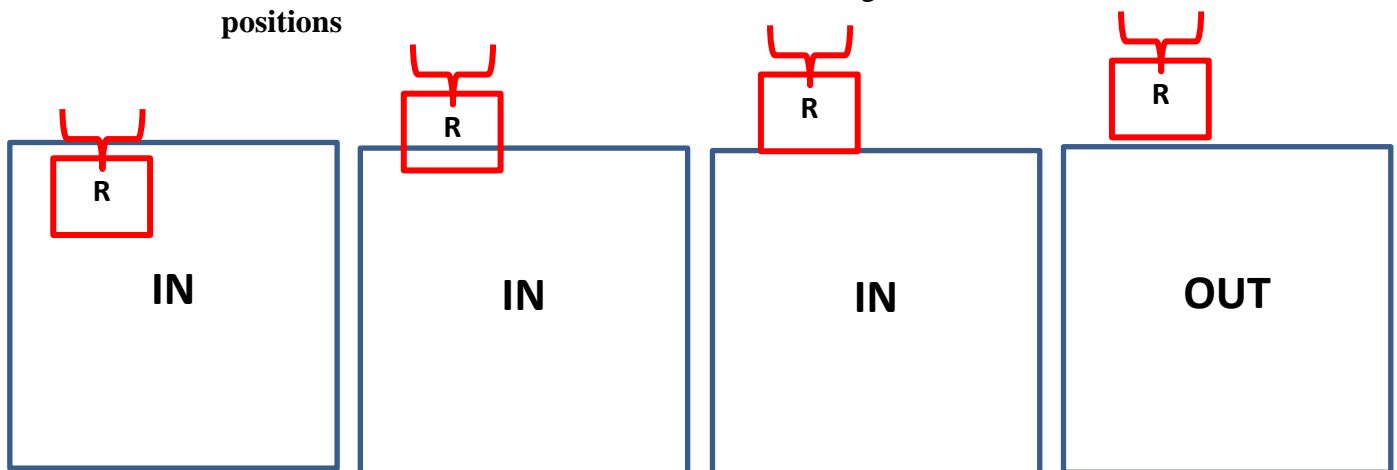

5. Judging

A group of specialized referees will be in charge of calculating the points scored by the participants, and supervising the completion of the competition's mission during all the Olympiad matches.

In Diving Robot category, three referees will be in charge; two will be stationed at the playing field to count the scores of the competing teams, and one will be supervising the match in general.

In Robo-Fight category, one referee will be in charge.

6. Best Robot Presentation

The Judging Committee of each Olympiad's category will choose the team with the best design and performance, to share with all the Olympiad's participants their experience with assembling their robots through a 10-minute presentation in a session on 28 November 2013. The teams performing at that session, will be most likely the teams who scored the highest points at the "Design Exam".

7. Awards

- Grand awards (first, second and third places)
- Special awards will be awarded to the best Robot Design and best Robot presentation.

8. Technical Support

Teams are welcome to send their queries and questions to the following email: robo.alex@bibalex.org

Please regularly check our webpage for any updates, as the Technical Support Committee will announce them online, webpage: <http://www.bibalex.org/en/psc/GetInvolved/Robotheca.aspx>